

Fauvel AV-36

Aile volante, 1951

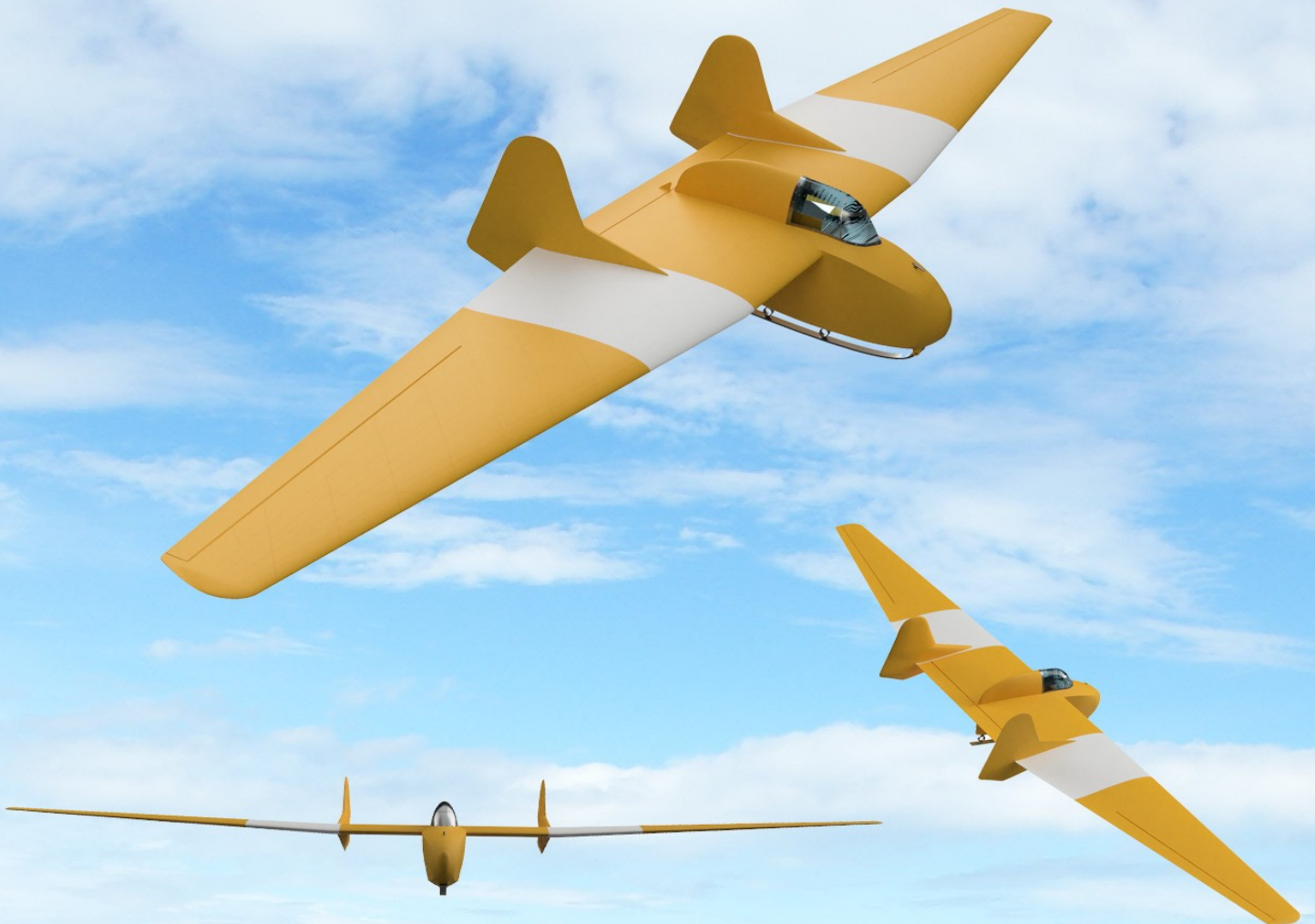

Wingspan	2000mm
All-up-Weight	1000-1500g
Airfoil	PB-771-mod195-95 / PB-773-mod160-85
Center of Gravity	65-70mm
Wingload	25-37g/dm ²
Materials	LW-PLA, PLA

What's it all about?

Our decision to produce our very first 3d-printable scale plane was purely emotionally inspired. It was a YouTube-Video from a flying buddy who slopesoared a glider that looked a bit like a mixture of a P-38 and a Citroen 2CV to me.

First I thought „what an ugly bird this is“ – but then I was somehow fascinated by the design and started researching.

The AV-36 is a flying wing, first maiden in 1951. It's designer is Charles Fauvel (1904 – 1979) who did quite a lot of other fascinating tailless planedesigns, but the AV-36 was the most successful one. The Original has a Span of 11,95m, an AUW of 225kg and is a singleseater and pure glider.

We decided to offer an optional Motorfuselage for those who don't have fancy slopes around and it came out the AV 36 is a lot of fun on the field as well.

What kind of Materials do I need?

4x10mm roundmagnets Neodym	10 pcs
8mm Carbontube (1-2mm thick) Spars	455mm (2x), 310mm (2x), 630mm (2x)
LW-PLA	ca. 550g
regular PLA	ca. 250g
TPU soft/medium	<20g
Servos 9g – SG90 or similar	3 pcs
RX of your choice (4CH)	1 pc
Battery 3000 mah 4S (motorized)	1 pc
optional Motor HK NTM Prop-Drive 28-36 1200KV / 530W + ESC 35-40A	1 pc
Servorods	50cm in total will do
CA-Glue + accellerator	best to have different viscosities!

Printsettings

The following settings are recommendations. Your individual, perfect settings highly depend on the used Material, your printer, your ambient temperature, humidity, etc. Please see them as a guideline and feel free to experiment. Default settings were created on a Prusa i3 MK3S using 0.4 Nozzle.

Category	A	B	C	D	E
Material	LW-PLA	LW-PLA	PLA	PETG	TPU
Layer height (mm)	0,25	0,25	0,2	0,25	0,2
Bottom Layers	2	2	3	3	4
Top Layers	3	3	4	4	4
Outer Walls	2	1	2	3	3
Infill	3,00% Gyroid	0%	25,00%	100%	100%
Nozzletemp	235°C	235°C	215°C	230°C	240°C
Bedtemp	60°C	60°C	60°C	80°C	50°C
Flow (%)	49,00%	49,00%	100,00%	100%	120%
Cooling	50,00%	50,00%	100,00%	30%	70-90%
Brim	yes	yes	none	yes	no
Support	none	none	none	no	no
Linewidth	0,45	0,45	0,45	0,45	0,45

If you want to increase strength or decrease weight of a part – feel free to increase outer Walls, decrease infill density, play with the wall thickness aka linewidth!

Printsettings

After defining the A, B and C – profiles in your slicer you can begin slicing the parts. We recommend to print the LW-PLA parts one by one if you use active foaming LW-PLA!

Part	Category	additional Settings
Cockpit	C	Infill 10%
Fus1-2 (M)	A	
Airspeedsensor	C	Layerheight 0.10, Supports
Nose (Glider/Release)	C	Supports
Elevator/Ailerons	C	1 outer Wall, 0% Infill, Brim
Finparts	B	*
Hatch	A	
Joinerparts	C	Infill 10%
Motoradapter	C	
Motormount	D	
Plughouse	C	
Rudderhorn	C	
Servoplates	C	
Servoframe	C	
Skid	D	
Suspension	E	
TPU_hinge	E	
WL1-5	B	*
Wingtips	A	

The STLs are already oriented in the right way in which they print perfect without supports!

*for best Results add heightrangemodifier to avoid printing a few lines midair (remove bottom and toplayer from 1mm to part height -1mm). Prints come out nice even without modifiers, but if you're a monk like me you use them ;) You can just use the 3mf files provided- they include the modifiers!

don't forget the additional settings for some of the parts! If you feel the need to reinforce certain areas feel free to use some meshmodifiers or individual processes. Our Testplanes have been printed with the above settings without further reinforcement!

Partweights

Part	appr. Weight
Cockpit	40g
Fus1	75g
Fus2(M)	80g
W2	40g
W3	27g
W4	15g
W5	13g
Wtip	2g
Elevator & Aileronparts complete L/R	57g
Joiners L/R complete	120g
Fin1	10g
Fin2	10g
Hatch	15g

Emptyweight complete: appr. 750 - 800g

Explosionview

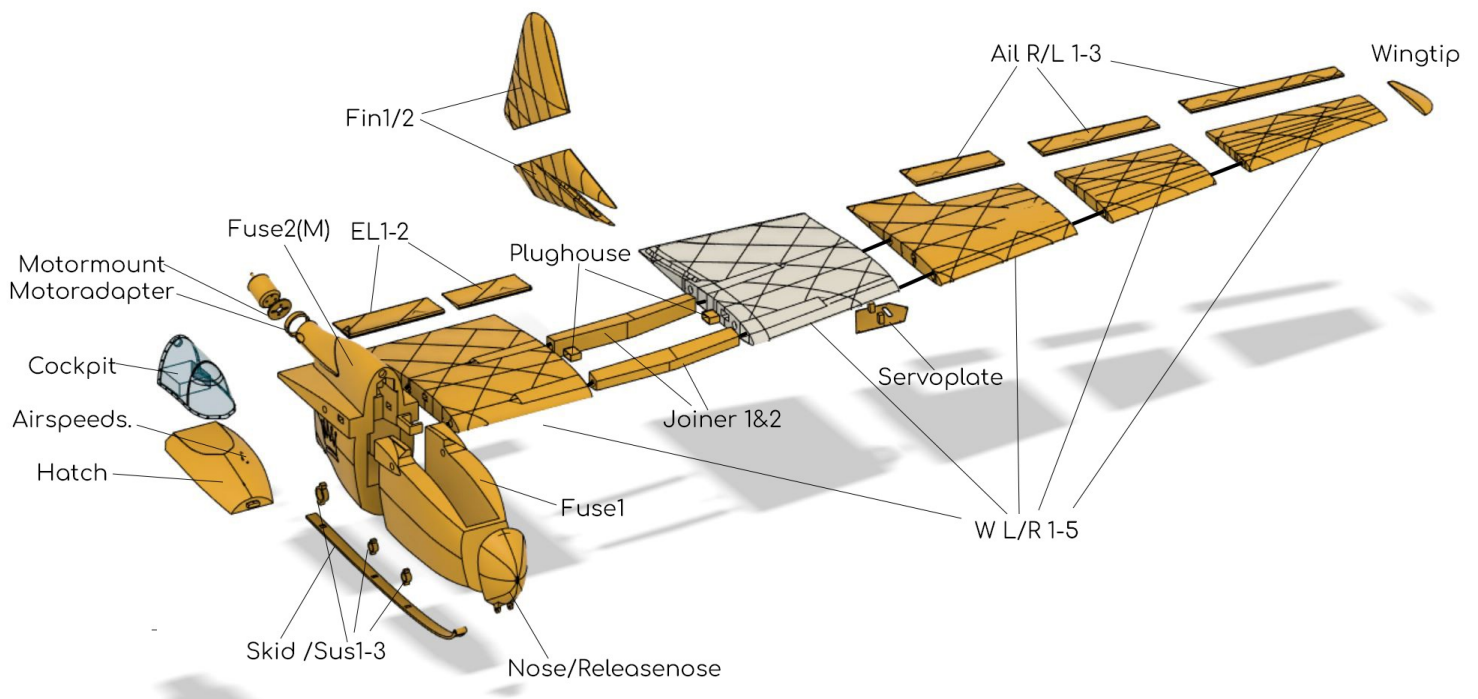

Wingassembly

The wings are detachable for easy transport. Make sure to glue in the joiners only on one side of the wing (Wing2) so that the other side can just be slid in at the field.

First testfit the Wingjoinerparts into the Wings - there will be some filamentstringing in the recess where the joiner goes into the wing, so carefully slide the joiners in and out to remove the residues until they slide in flawless.

Start Wingassembly by joining „W L/R 2“ with „Joiner 1“ and „Joiner2“ with medium CA, using the corresponding carbontubes as guiderails. Go on the same way with Wingparts 3-5 and keep in mind, that you won't be able to remove the Carbontubes once you joined W L/R 3 & 4 !

Finally glue on the Wingtip. You can also delay this step, which can make aileroninstallment a bit easier. 4 Pcs of round of roundmagnets ensure the wing doesn't come off midflight - mind the orientation before glueing them in ;)

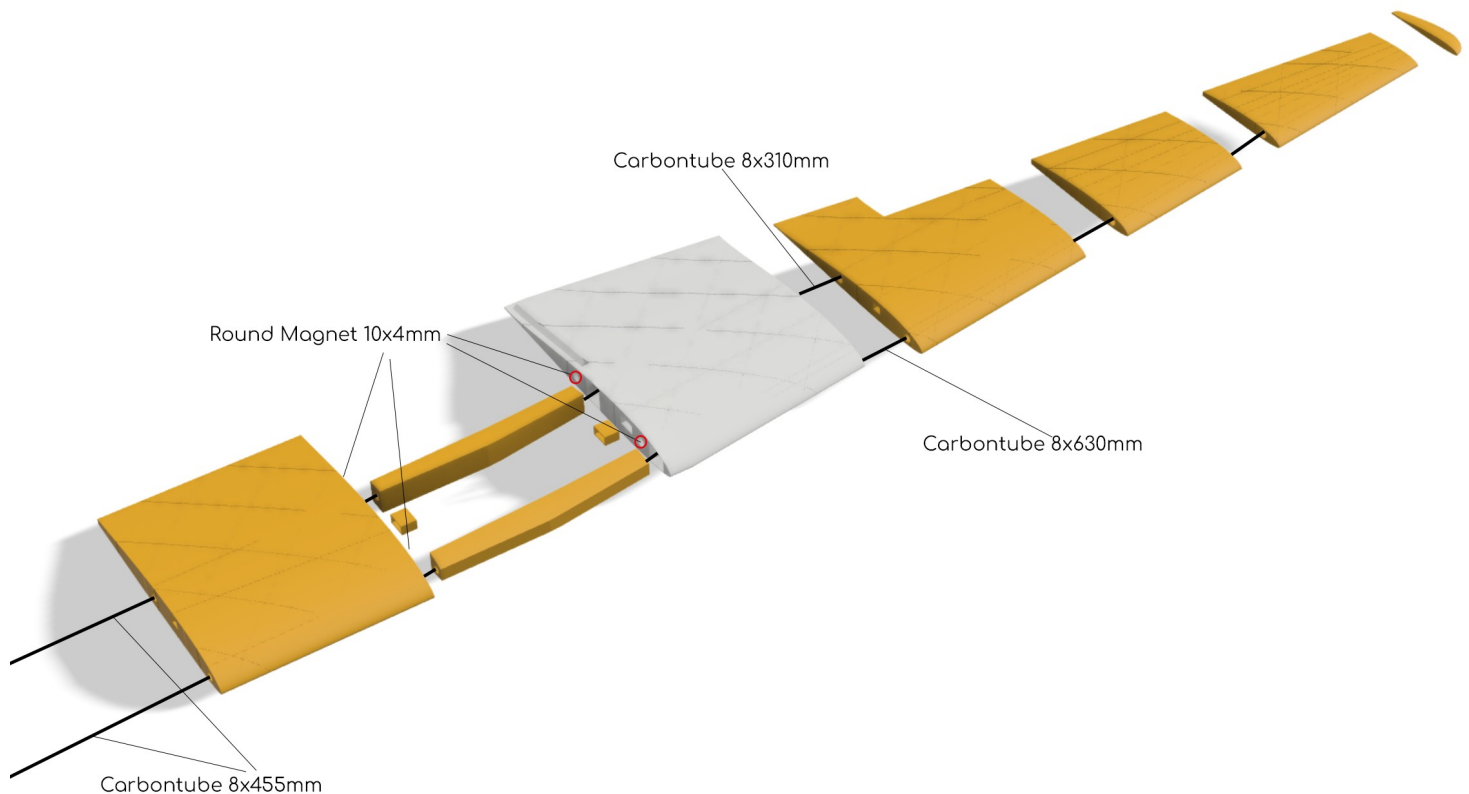

Fuselageassembly

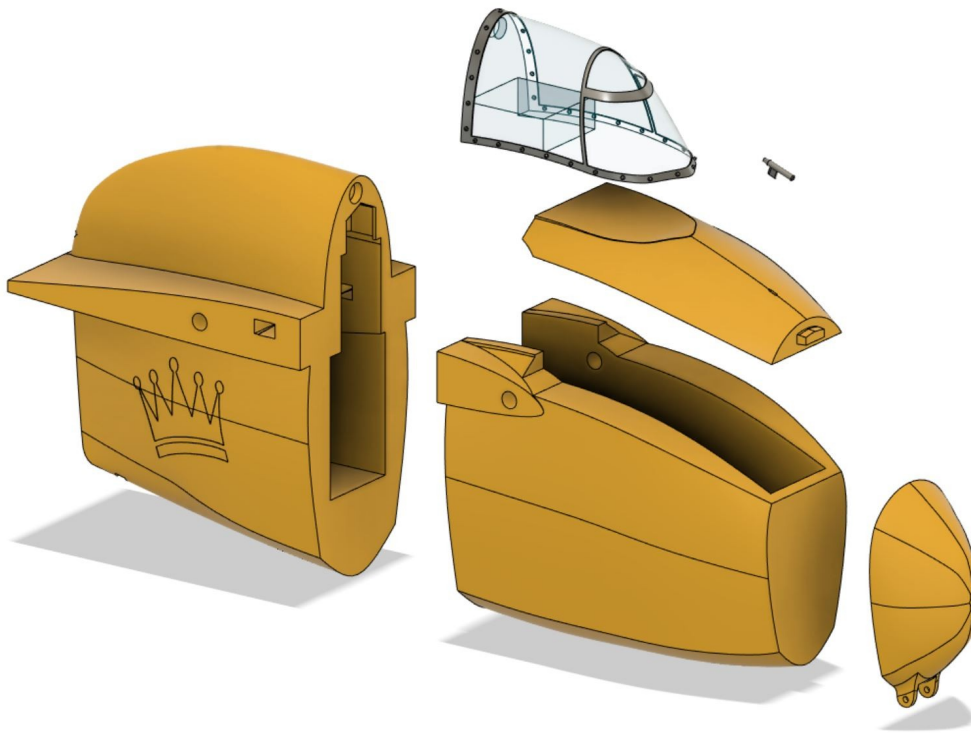

Fuselageassembly is pretty straight forward – just align the parts „Fuse1“ and „Fuse2(M)“ and glue them together with some medium CA. Then do the same with „Cockpit“ and „Hatch“. Add 2pcs 10x4mm roundmagnets into the recess at „Fuse2(M)“ and „Cockpit“ (mind the orientation). It’s a good idea to wait with the final noseinstallation until you are in the process of adding trimlead, as the nose is the best place to store it (unless you use the releasenose). You can either just glue on the nose or use the „noseplate“ together with some screws which go through the fuselage into the nose.

Releasenose

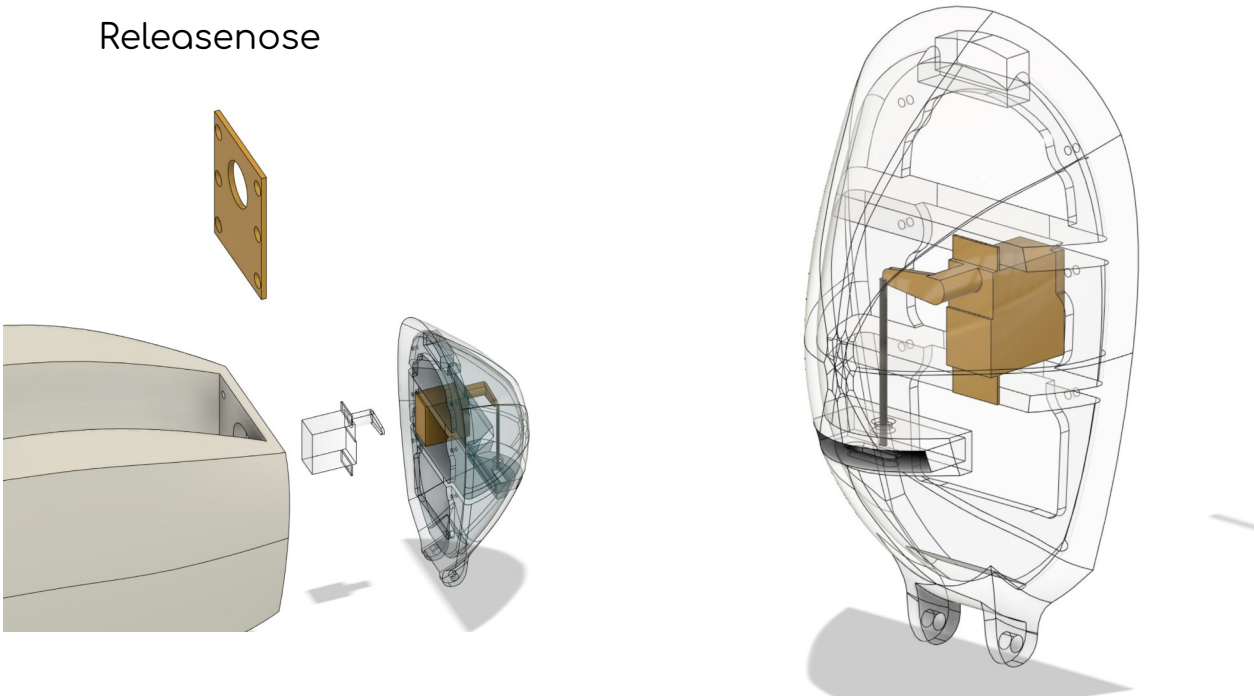

If you want to install the releasenose for glidertowing you'll need a microservo like Hitec HS-50 or similar. Fix the servo with some CA or hotglue in the nose, but first install the steelwire for the release-mechanism as it won't be accesible once the servo is glued in place.

The slot fits standard keychainrings, so you can open the release, put in the keyring and close it.

To get a good joint between Fuse1 and the Nose use the „Noseplate“ with some short woodscrews to drive trough Fuse1 into the corresponding holes in the nose. It's a bit of a fiddeling, but with a slick screwdriver it will be ok.

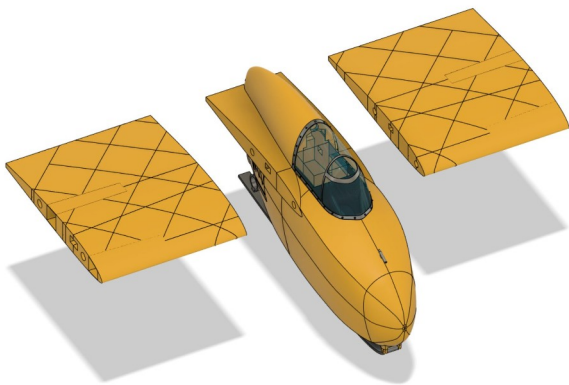

Now join the W1 parts to the Fuselage once again using the carbontubings as guiderails. Use CA for this as well. W1 parts will stay on the fuselage, only the rest of the wings is detachable. Mind the servocables!

Finally you can install the skid. Try to fuse the 2 halves of the skid by heating them with a lighter or a hotgun and carefully press them together. Afterwards glue the „Sus1-3“ parts to the skid with enough CA. Lastly (you guessed it)

-fix the suspension parts to the fuselage using CA. Then take a M3x25 Screw and nut for the axle where the skid joins the nose. You can also use a corresponding carbonrod and prevent it with thick drops of CA from slipping out of its intended place.

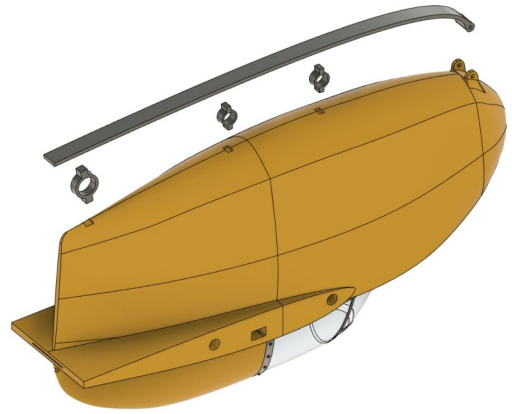

Ailerons, Elevator

First use CA medium to join the parts. Make sure to glue them in the right order and direction. The airfoil has a significant S-Shape so you can easily see which side is up if you take a look at the aileron segments from the side.

The Ailerons and Elevator are hinged with TPU-hinges. It's a good practice to testfit every single hinge before adding glue. Then glue them to the aileron without accelerator, put glue on the other side of the hinges, carefully insert the hinges into the slots in the wing and only if everything went fine add accelerator to the slots. Wiggle around the ailerons while the CA cures so they go easily later

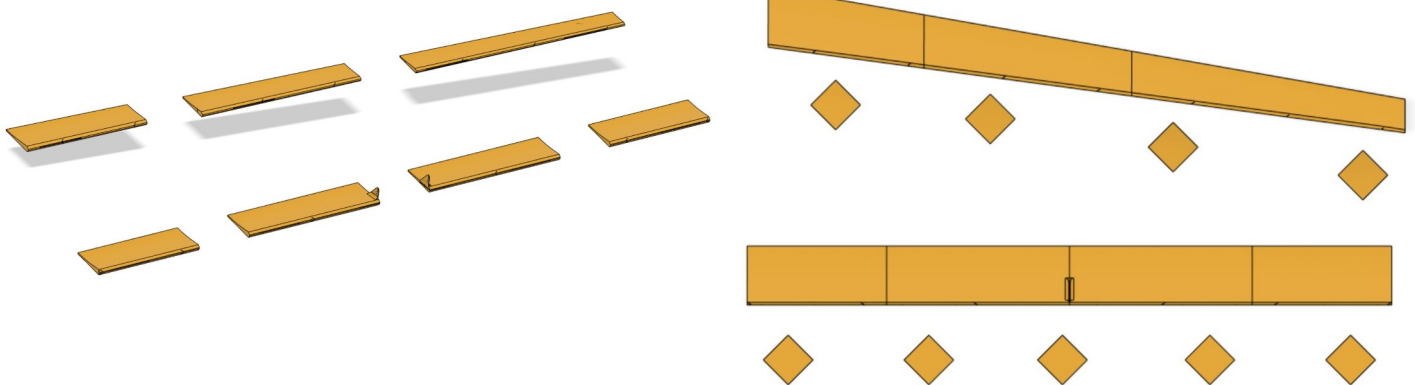

Servo and Plug installment

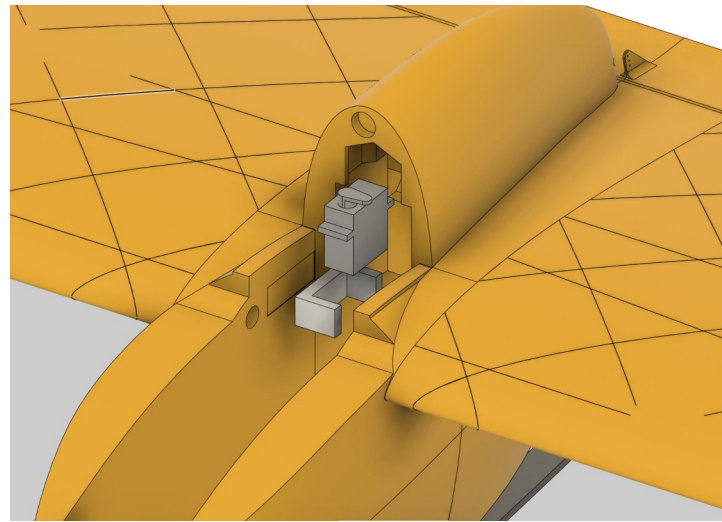
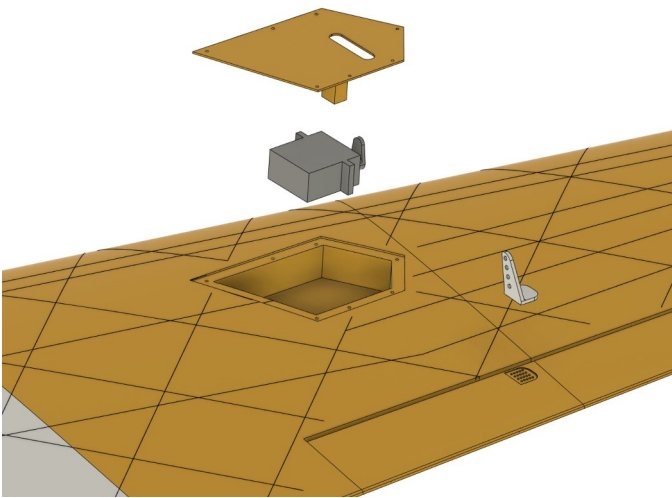

The wingservos go onto the „servoplates“ with regular screws, use a hot piece of steelwire to add a hole where you need to screw it down. The plates can be fixed to the wing with servoscrews as well.

Servorecommendation: SG90 / Savöx SH-0264MG

The fuselageservo sits in the „servoframe“ which is glued to „fuse1“.

For easy wingdetachment you can connect MPX-Plugs to your servowires and glue them into the „plughouse“ parts which are then glued into the wings:

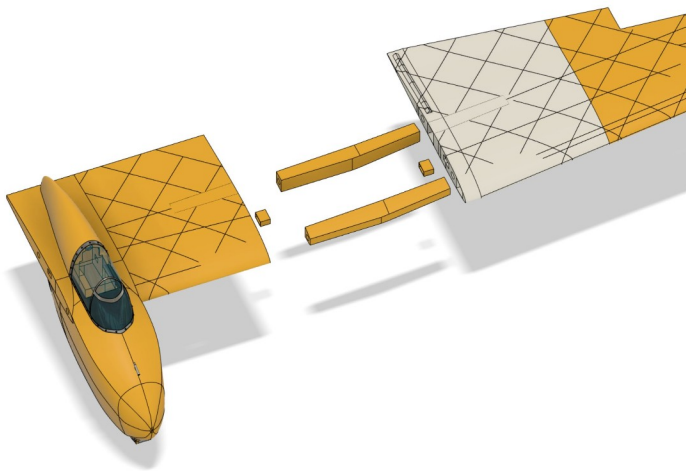

Finassembly

Join Fin1&2 parts, clean the stringing in the recess where the fins join the wing and testfit them onto the wing. They just slide on the guiderail on the wing. If they don't fit right sand down residues of LW-PLA. Then put some thick CA onto the rails on the wing, slide on the fin and use some acellerator whilst making sure to press down the fin to eliminate any gap. You can still use thin CA to fill small gaps.

Motorassembly

The motorversion „Fuse2M“ features a wirechannel, two different „motoradapter“ parts with different angles and the motormount. We have not tested „motoradapter2“ (which has a lot more angle) yet as we prefer just mixing some up elevator to the throttle.

Recommendations:

[HK NTM Prop Drive 28-36 1200KV /530W](#)

[50a ESC with BEC](#)

9x8 Foldingprop (pusherhub required)

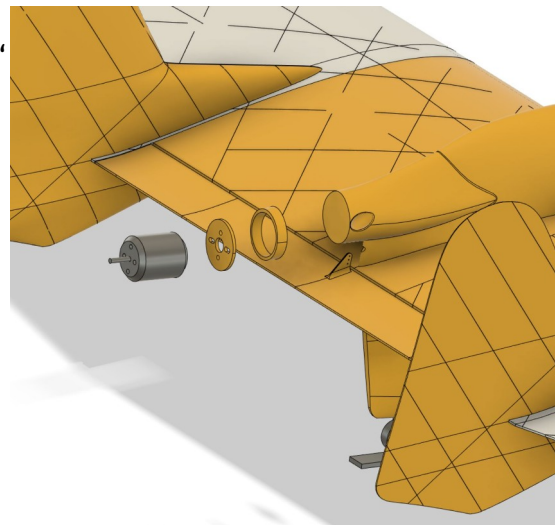

You can find a printable prop in the STLs.

Disclaimer:

Please be careful with printed props and always make sure the prop is balanced well. Test it with enough safety precaution to not get hurt! As printed Props can be dangerous we want to explicitly mention here, that we do NOT RECOMMEND to actually print and use them, and we are not responsible for any damaged caused by exploding props.

However we use them in our Prototypes and under the right circumstances they can work absolutely well. Print them from PLA with leading edge down and enough supports.

With a 3000mah 4S the AV 36 doesn't need much trimming lead and goes nearly vertical. If you want to expand endurance a 3S 5000mah will do as well – just check how the whole thing balances.

CG, throws, first flights

Center of Gravity

For Planks the CG is an extremely important value so it's absolutely essential to dial it in well. During testing we came to a value of 65-70mm behind the leading edge which corresponds to the markings on the underside of the „Wing1“ parts. Its a good practice to have the CG more in the front end of the spectrum for the very first flight and then dial it in to your needs.

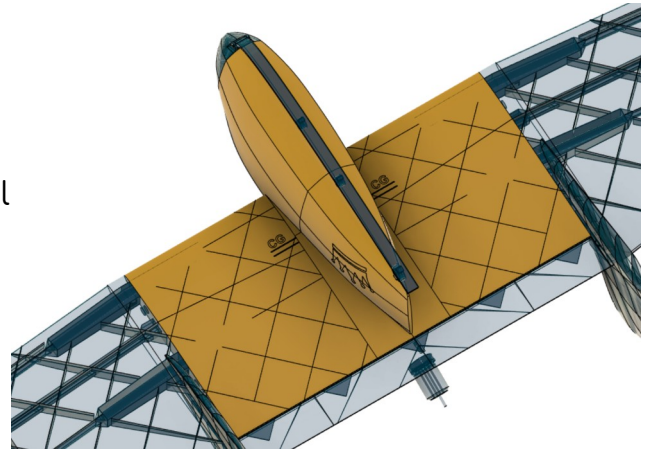

Throws

Neutral: 2.5mm up for ailerons and elevator

Elevator: elevator +23/-12mm /// ailerons mixed in: +12/-4mm

Aileron: +22/-13mm

+ means flap goes up, - means flap goes down

You will need to mix some up elevator (15-20% with the regular motoradapter) to the throttle to compensate motorpositioning.

First flights

When CG is dialed in and throws are ok you can take your „AV-36“ for a first flight. If you have a motor with 4S battery it's best to not start with full throttle- 50-75% will do and give you more time to react! If you have a pure glider it's good to have the advantage of a slope bringing as much air between the ground and your plane as possible. Don't stall the AV-36 and especially in tight turns you should mind airspeed, otherwise it could spiral to the ground. Just like a beautiful french lady this plane has some temperament, but it will reward you with hours of pure joy in the air if you treat her right.

Wish you a lot of good airtime with the AV-36!